

reflecta TV Stand 110M-12060 motorized / gunmetal grey

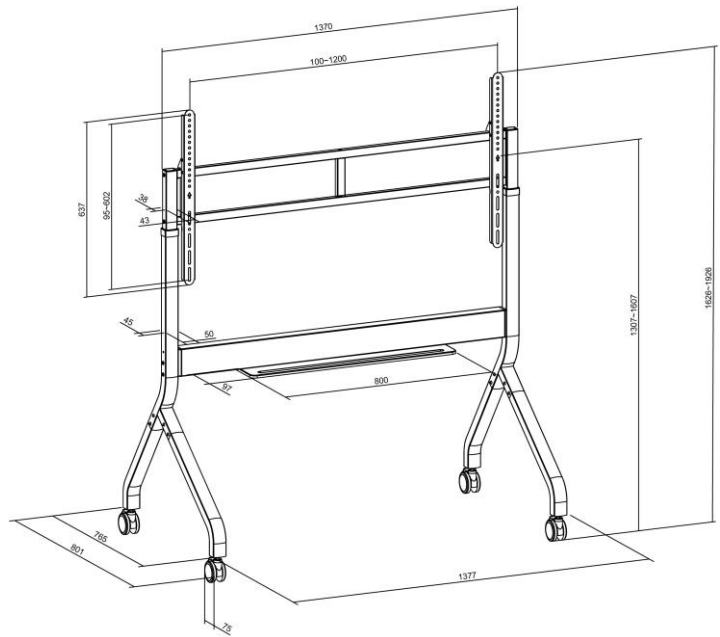

60-110"
152-279 cm

max.
120 kg

TV

max.
3 kg

DVD

VESA
100x100 200x100
200x200 400x200
300x300 400x300
600x200
400x400

VESA
600x300 600x400
800x400 600x600
800x600 900x600
1000x600
1200x600



Product information:

- Motorized height-adjustable TV-Stand
- Max. loading weight (TV): 120 kg
- Max. loading weight (shelf): 3 kg
- 60"-110" (152-279 cm)
- Height-adjustable (TV): 130.7-160.7 cm
- VESA: 100x100, 200x100, 200x200, 400x200, 300x300, 400x300, 600x200, 400x400, 600x300, 600x400, 800x400, 600x600, 800x600, 900x600, 1000x600, 1200x600
- Direction indicator
- Material: Steel (powder coated), plastic
- Dimensions: 137.7x80.1x162.6-192.6 cm
- Casters with locking mechanism
- RF remote control included

Code: 23249

EAN: 4005039232497

Specifications subject to change without prior notice.

reflecta gmbh
Merkurstrasse 8
D 72184 Eutingen
Phone: +49 (0) 7457 9465-60
Fax: +49 (0) 7457 9465-72
e-mail: mail@reflecta.de
http: www.reflecta.de